

Art.: 3046

Válvula de esfera con racor 2 piezas / Ball valve with 2 pieces connector

Características	Features
1. Válvula de esfera con paso total.	1. Ball valve with full bore.
2. Construcción en latón s/ UNE-EN 12165 cromado.	2. Brass construction acc/ to UNE-EN 12165 chrome plated.
3. Extremos rosca gas (BSP) macho-hembra s/ ISO 228/1. Un extremo racor dos piezas.	3. Thread ends gas (BSP) male-female acc./ to ISO 228/1. One end two piece connector.
4. Accionamiento mediante palomilla aluminio.	4. Working by means of aluminium T-handle.
5. Temperatura de trabajo desde -20°C a 110°C.	5. Working temperature from -20°C to 110°C.
6. Presión máxima de trabajo 25 bar (PN 25).	6. Maximum working pressure 25 bar (PN 25).
7. Asientos PTFE.	7. PTFE Seats.

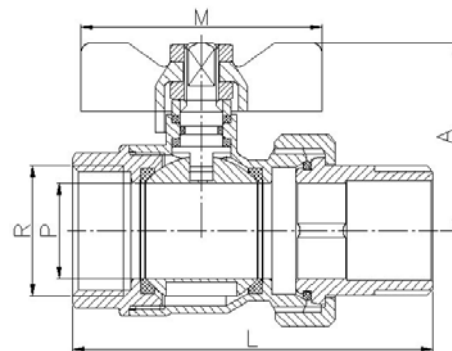
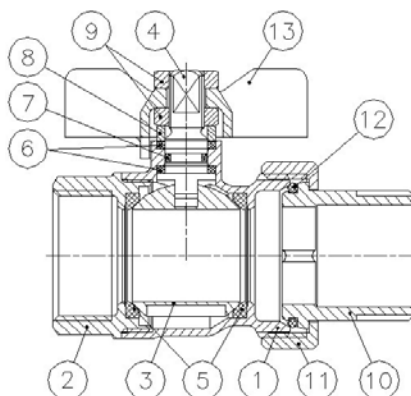

Nº	Denominación / Name	Material	Acabado Superficial / Surface Treatment
1	Cuerpo / Body	Latón / Brass (CW617N)	Granallado + Cromado / Peened + Chromed
2	Tapa / Cap	Latón / Brass (CW617N)	Granallado + Cromado / Peened + Chromed
3	Esfera / Ball	Latón / Brass (CW617N)	Cromado / Chrome plated
4	Eje / Stem	Latón / Brass (CW617N)	Cromado / Chrome plated
5	Asientos / Ball seats	PTFE	-
6	Anillo prensa / Stem packing	PTFE	-
7	Tórica / O-Ring	NBR	-
8	Anillo prensa / Stem ring	Latón / Brass	Cromado / Chrome plated
9	Tuerca / Nut	Latón / Brass	Cromado / Chrome plated
10	Conexión / Male connection	Latón / Brass	Cromado / Chrome plated
11	Tuerca / Nut	Latón / Brass	Granallado + Cromado / Peened + Chromed
12	Tórica / O-Ring	NBR	-
13	Maneta / T-Handle	Aluminio / Aluminium	Pintado / Painted

Ref.	Medida / Size		Dimensiones / Dimensions (mm)				Peso / Weight (Kg)
	R	P	A	L	M		
3046 04	1/2"	14	36	69	50	0,185	
3046 05	3/4"	19	44	76	62	0,305	
3046 06	1"	24	48	92	62	0,490	
3046 07	1 1/4"	30	57	106	78	0,715	

DIAGRAMA PÉRDIDA DE CARGA / HEAD LOSS CHART

(Válvulas paso total roscadas / Threaded ends full bore ball valves)

Valores de Kv / Kv Values:

Kv = Es la cantidad de metros cúbicos por hora que pasará a través de la válvula generando una pérdida de carga de 1 bar.

Kv = The flow rate of water in cubic meters per hour that will generate a pressure drop of 1 bar across the valve.

Medida / Size	1/2"	3/4"	1"	1 1/4"
Kv	16	30	45	70

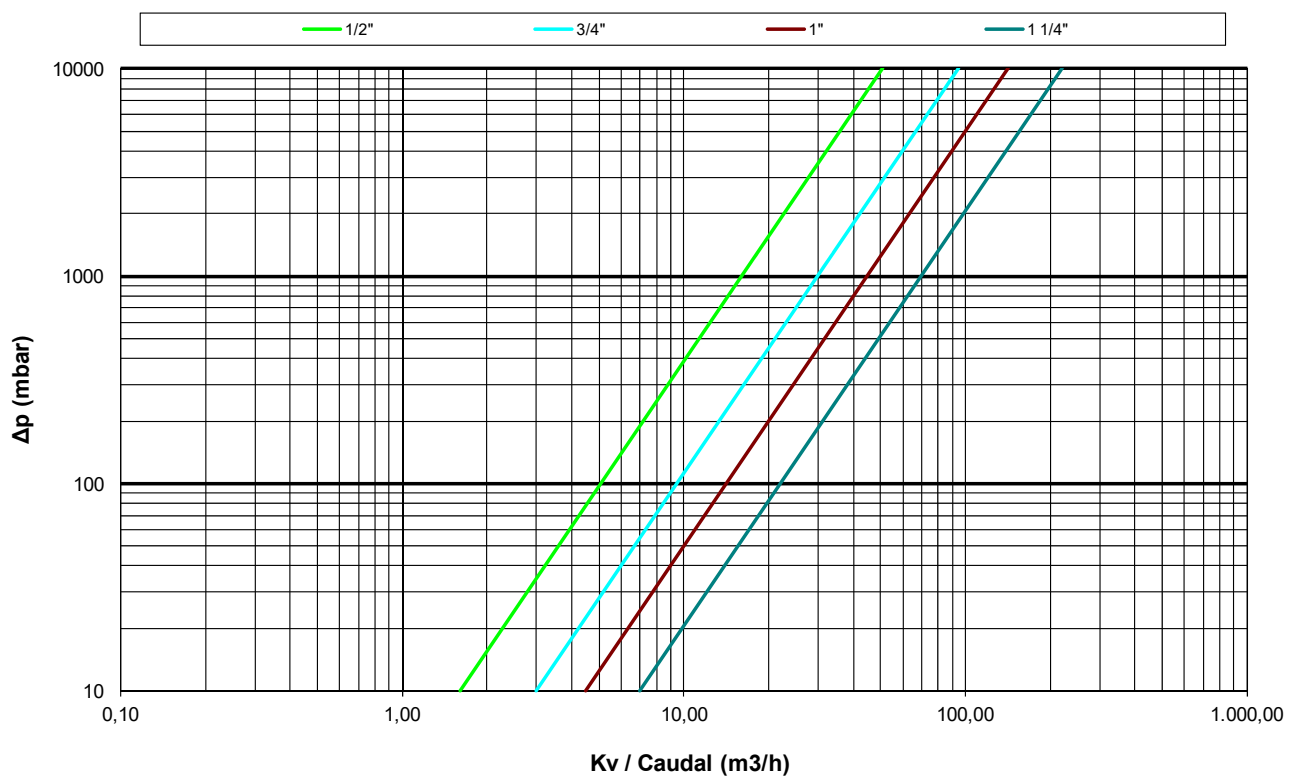

CURVA PRESIÓN - TEMPERATURA / PRESSURE - TEMPERATURE RATING

